

Caproni

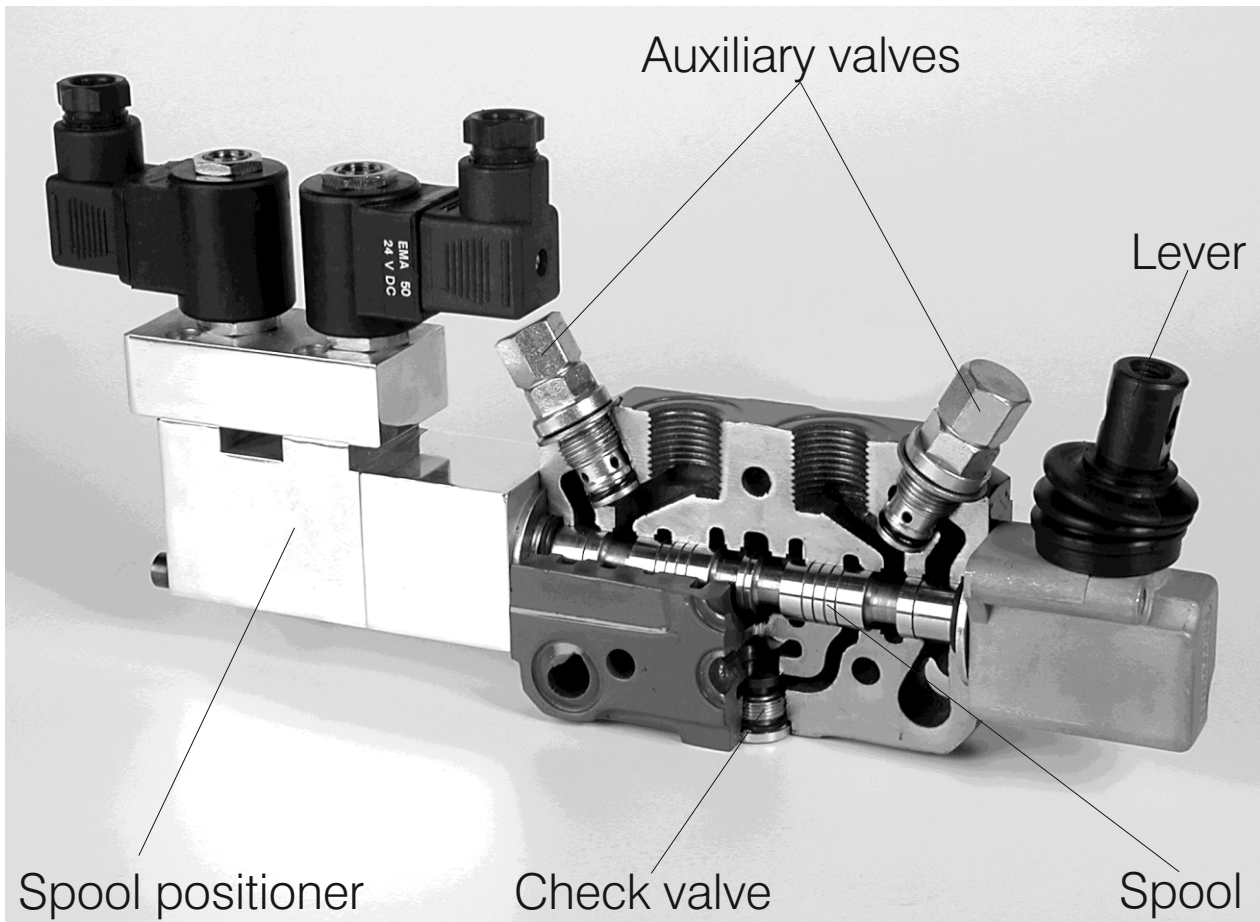

SECTIONAL DIRECTIONAL CONTROL VALVES



CONTENTS: Page

-Technical data.....	2/14
-Circuit mode.....	2/14
-Dimensions RP80.....	3/14
-Dimensions RP60.....	4/14
-Lever mechanism.....	5/14
-Remote control.....	6/14
-Joystick control.....	6/14
-Micro switch option.....	6/14
-Main relief valves.....	7/14
-Service and auxiliary valves.....	7/14
-Mounting service and auxiliary valves examples.....	7/14
-RP80 with on/off electrohydraulic control-internal pilot.....	8/14
-RP60 with on/off electrohydraulic control-internal pilot.....	9/14
-Spools/spool control.....	10/14
-Inlet cover/outlet cover.....	11/14
-Ordering code RP80.....	11/14
-Ordering code RP60.....	12/14
-Hydraulic circuit application.....	12/14
-Performance curve RP80.....	13/14
-Performance curve RP60.....	14/14

Directional control valves RP80 and RP60 are sectional type, with manual operation. They provide parallel or tandem distribution of the working liquid and its direct flow to the tank without activating the sections. They consist of inlet cover with integrated relief valve, a combination of sections (up to 10pcs) and outlet cover.

STANDARD FEATURES:

1. Adjustable main relief valve
2. Internal load holding check valves integrated in each section
3. Adjustable auxiliary valves are available
4. Balanced interchangeable spool (provides minimum leakage, smooth operation)

TECHNICAL DATA

PARAMETERS	UNITS	RP80	RP60
Rated flow	l/min (US GPM)	80 (21.1)	60 (15.8)
Rated pressure	bar (PSI)	250 (3571)	320 (4570)
Max. back pressure	bar (PSI)	18 (257)	30 (428)
Spool leakage at: p=100 bar.; t=40°C and viscosity 36cSt	cm ³ /min (in ³ /min)	max 6 (0,36) max 2 (0,12) on request	
Max. number of section		10	
Working liquid - hydraulic oils with parameters:			
-viscosity	mm ² /sec (cSt)	15...300	
-recommended viscosity	mm ² /sec (cSt)	20...80	
-temperature	°C (°F)	-20...+80 (-4...+176)	
-degree of filtration	mm (in)	0.025 (9.8 10 ⁻⁴)	

CIRCUIT MODE

STANDARD PARALLEL CIRCUIT

The open center passage is closed off when spool is fully shifted and hydraulic oil will flow directly to the power core passage, making oil available to all work ports. The hydraulic oil can be divided so that it will flow to two or more functions by metering the spools. The parallel circuit is the most commonly used circuit in mobile equipment, because thanks to metering, more than one function can be operated at the same time at random in the valve bank assembly.

CODE P

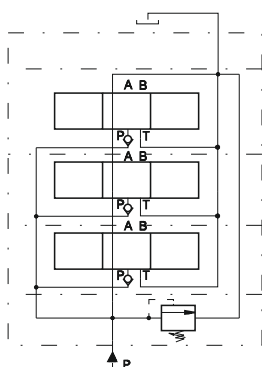

TANDEM CIRCUIT

Hydraulic oil available to the work ports through the open center passage. When an upstream spool is fully shifted, oil is available to a downstream section in a tandem circuit. The upstream section has priority.

CODE T

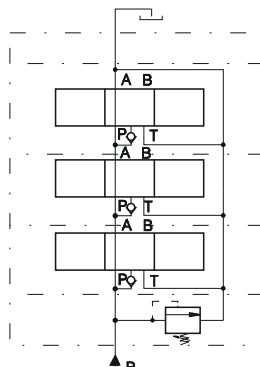

COMBINATIONS OF PARALLEL AND TANDEM CIRCUIT

For realizing of combined acting first have to be arranged the section with parallel acting followed by those with tandem acting.

CODE C

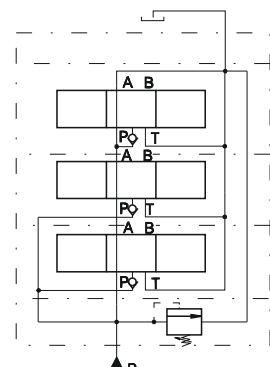

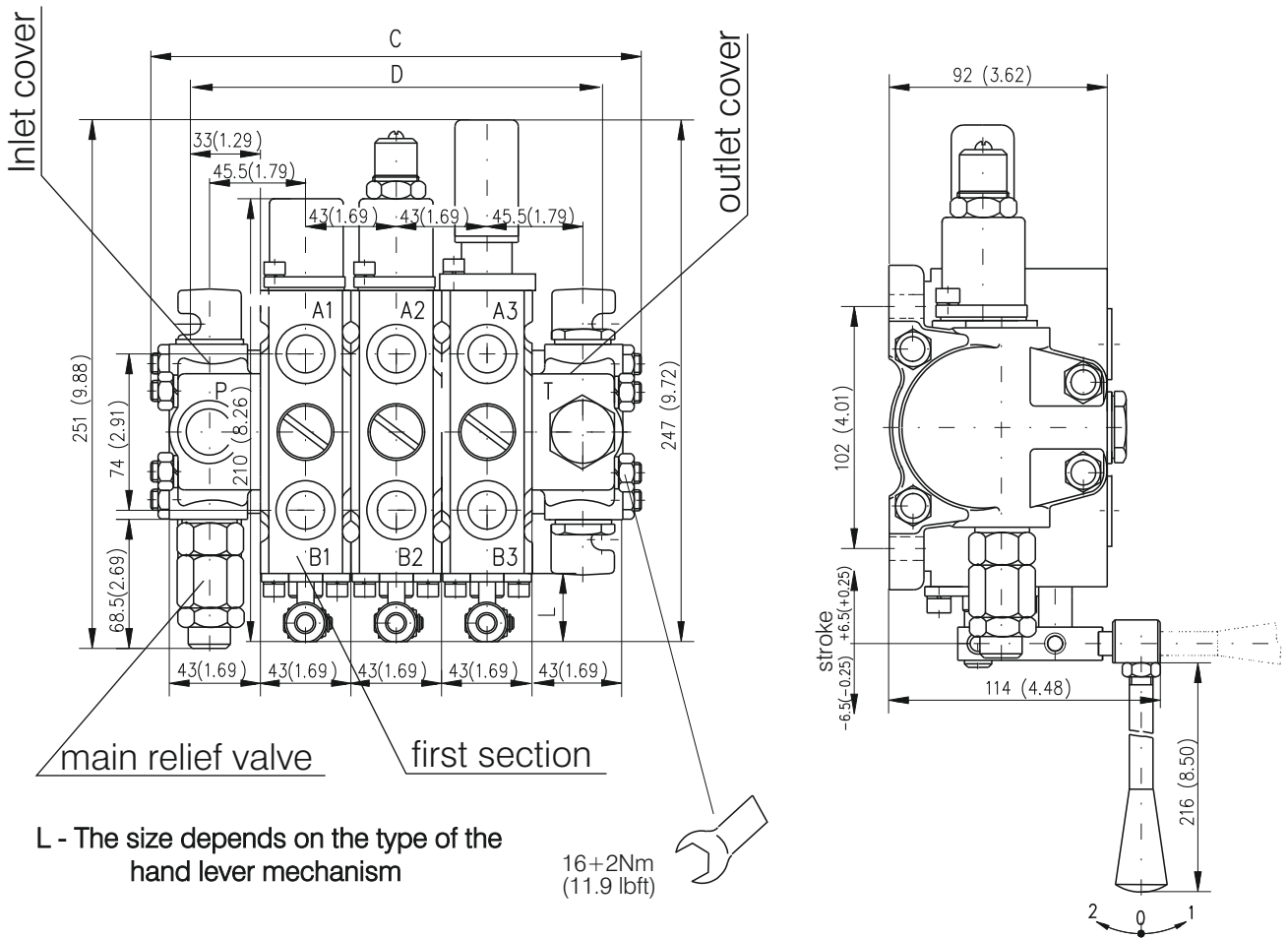

L - The size depends on the type of the hand lever mechanism

16+2Nm
(11.9 lbft)

If the lever moves from 0 to 2 the flow passes to port B

Four bolts M8 fix sectional valve assembly to the place of mounting.

TYPE	C mm (in)	D mm (in)
RP80/1 *	146 (5.74)	109 (4.29)
RP80/2	189 (7.44)	152 (5.98)
RP80/3	232 (9.13)	195 (7.67)
RP80/4	275 (10.82)	238 (9.3)
RP80/5	318 (12.5)	281 (11.06)
RP80/6	361 (14.21)	324 (12.75)
RP80/7	404 (15.90)	367 (14.44)
RP80/8	447 (17.59)	410 (16.14)
RP80/9	490 (19.29)	453 (17.83)
RP80/10	533 (20.98)	496 (19.52)

* Number of sections

Standard available threads

Ports	BSP (ISO 228)	METRIC
P	G 1/2	M24x1.5
A,B	G 1/2	M20x1.5
T	G 1/2	M24x1.5

NOTE: All dimensions are shown in mm (in)

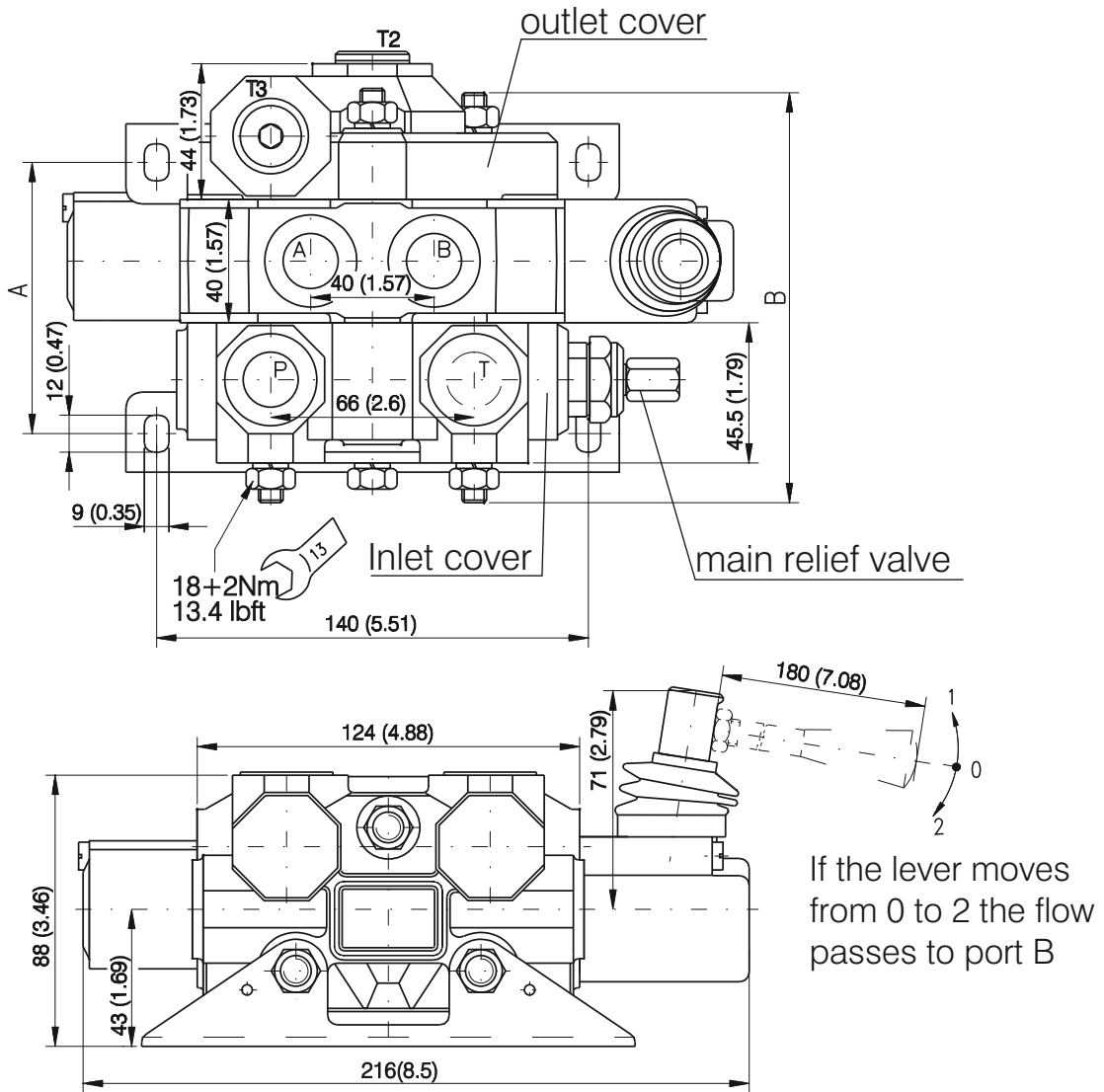

N. of sections	Dimension A mm (in)	Dimension B mm (in)
1	74 (2.91)	126 (4.96)
2	114 (4.48)	166 (6.54)
3	154 (6.06)	206 (8.11)
4	194 (7.64)	246 (9.69)
5	234 (9.21)	286 (11.26)
6	274 (10.79)	326 (12.83)
7	314 (12.36)	366 (14.41)
8	354 (13.94)	406 (15.98)
9	394 (15.51)	446 (17.56)
10	434 (17.09)	486 (19.13)

Standard available port threads
P, T, A, B: G3/8, G1/2

NOTE: All dimensions are shown in mm (in)

Code

- E without lever
- EL with standard hand lever

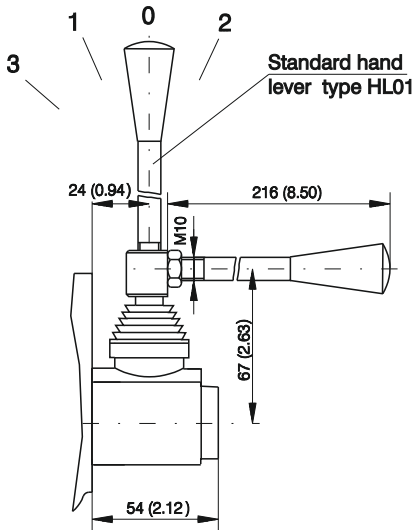

Code

- EO - without lever
- ELO - with standard hand lever

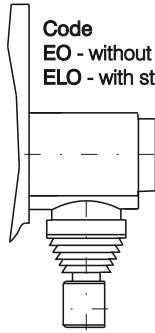

Code

- RK without lever
- RKL with standard lever (L=200mm.)

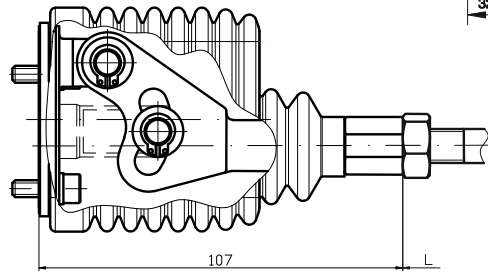

Code F

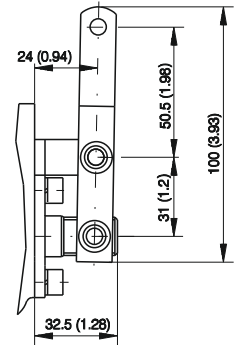

Code

- S without lever
- SL with standard hand lever

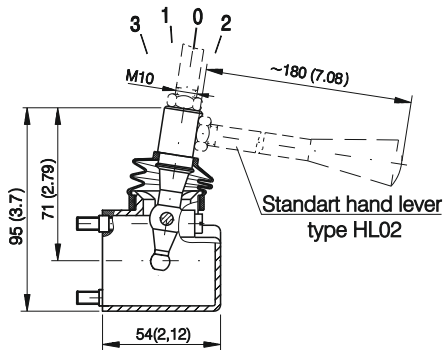

Code

- SO without lever
- SLO with standard hand lever

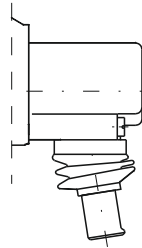

Code

- RK without lever
- RKL with standard lever (L=200mm)

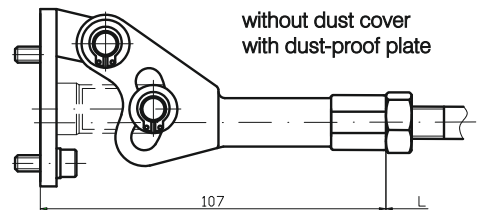

Code

SGO safety lever with lock in neutral

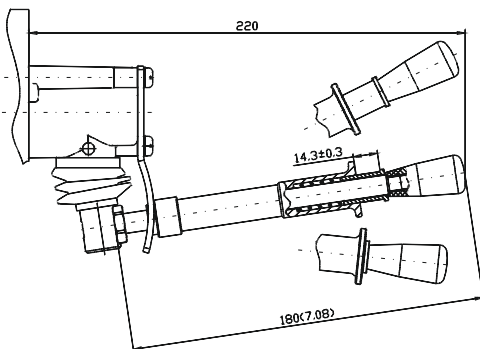

Code

SG safety lever with lock in neutral

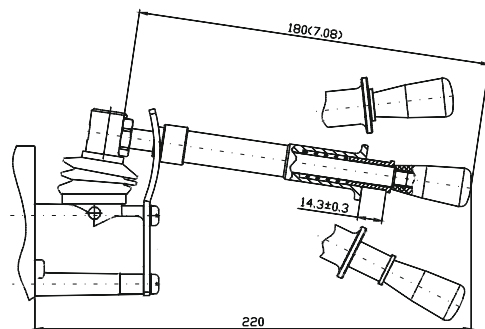

Code H

cabels and cabel controls on request

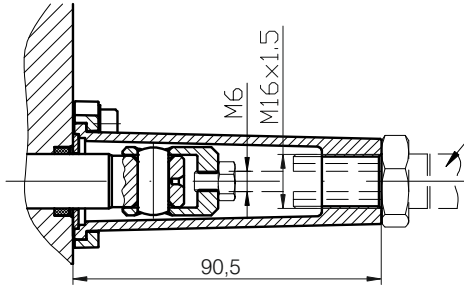

Code Z

with dust-proof plate

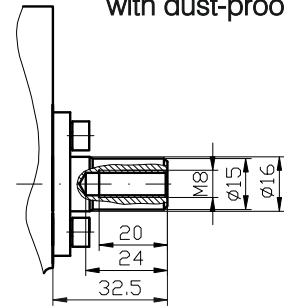

JOYSTICK CONTROL

RP80

RP60

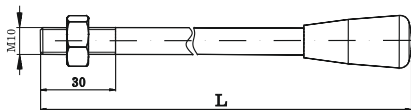
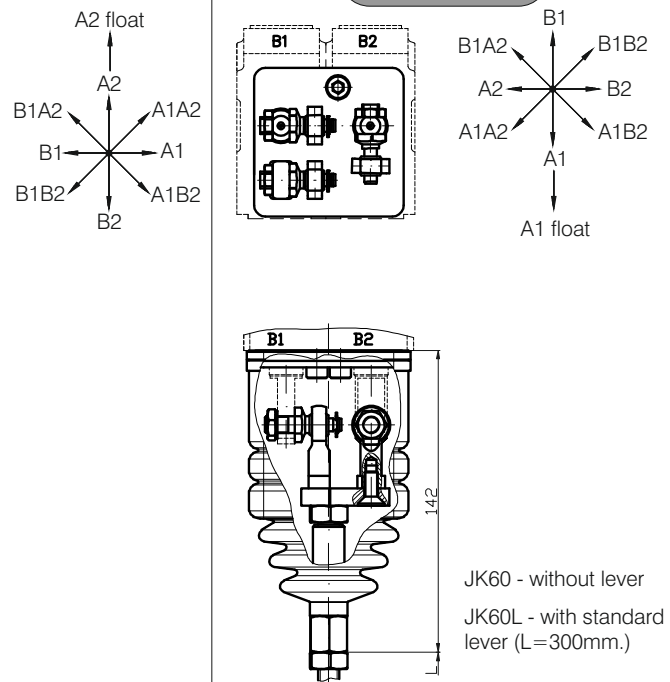
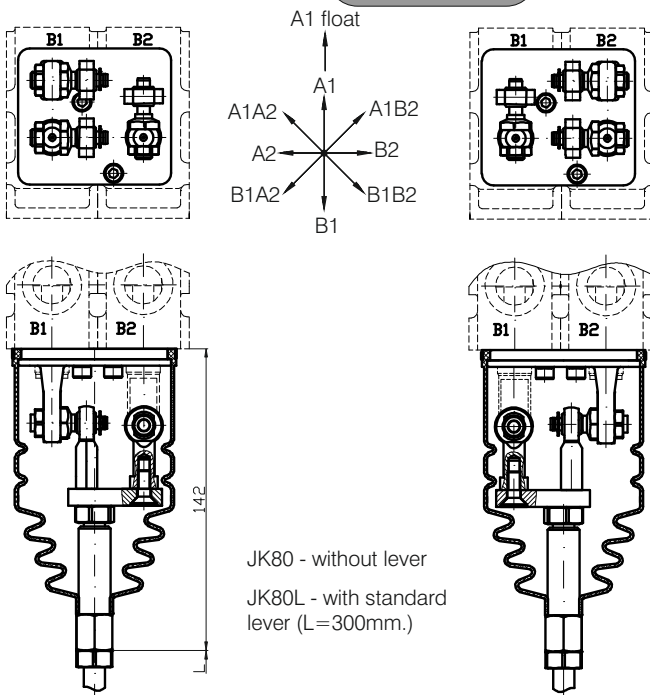

Different lever length L available on request.

MICRO SWITCH OPTION

RP80&RP60

micro switch:
max. current/voltage - 5A/250V AC
protection - IP67
contact configuration

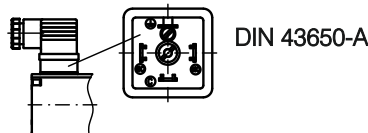
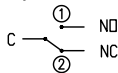

Code	
Omit	without microswitch
E1	
E2	
E3	

MAIN RELIEF VALVES

RP80

KP-70 (pilot operated pressure relief valve)

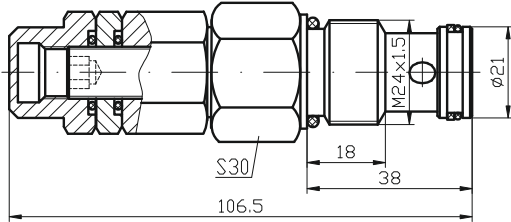

TYPE	Q _{nom}	P _{nom}	P _r
	l/min	bar	bar
KP-70/01	70	320	30...320
KP-70/02	70	200	15...200

RP60

KP60 (direct operated pressure relief valve)

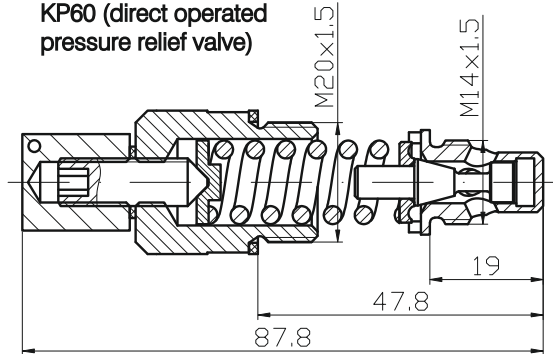

TYPE	Q _{nom}	P _{nom}	P _r
	l/min	bar	bar
KP60/01	60	210	96...210
KP60/02	60	320	211...320
KP60/03	60	100	30...100

SERVICE AND AUXILIARY VALVES

RP80&RP60

Relief + anticavitation valve

Code C

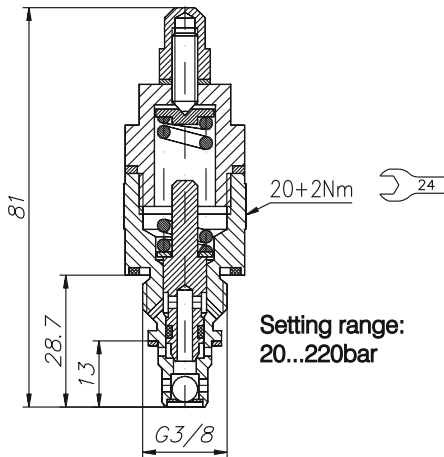

Pressure relief valve

Code RV

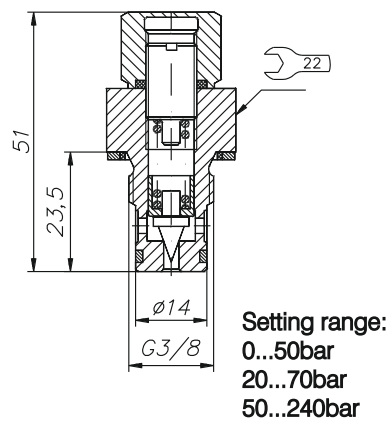

Anticavitation valve

Code KA 3/8

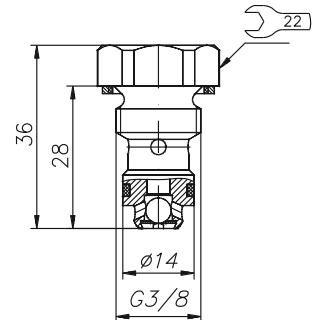

MOUNTING SERVICE AND AUXILIARY VALVES EXAMPLES

RP80

Steel blocks are available according to spool control options.

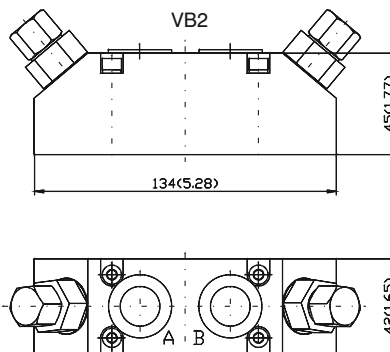
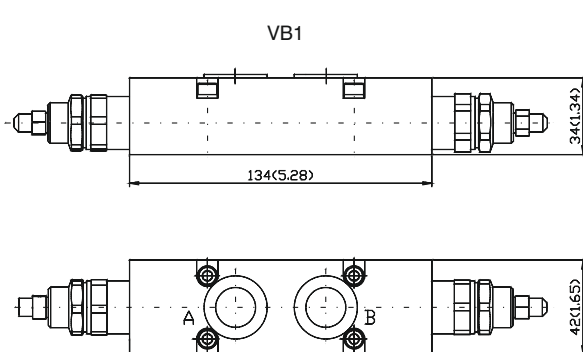

RP60

For RP60 auxiliary valves are mounted directly on section body.

RP80 EHI Dimensional drawing

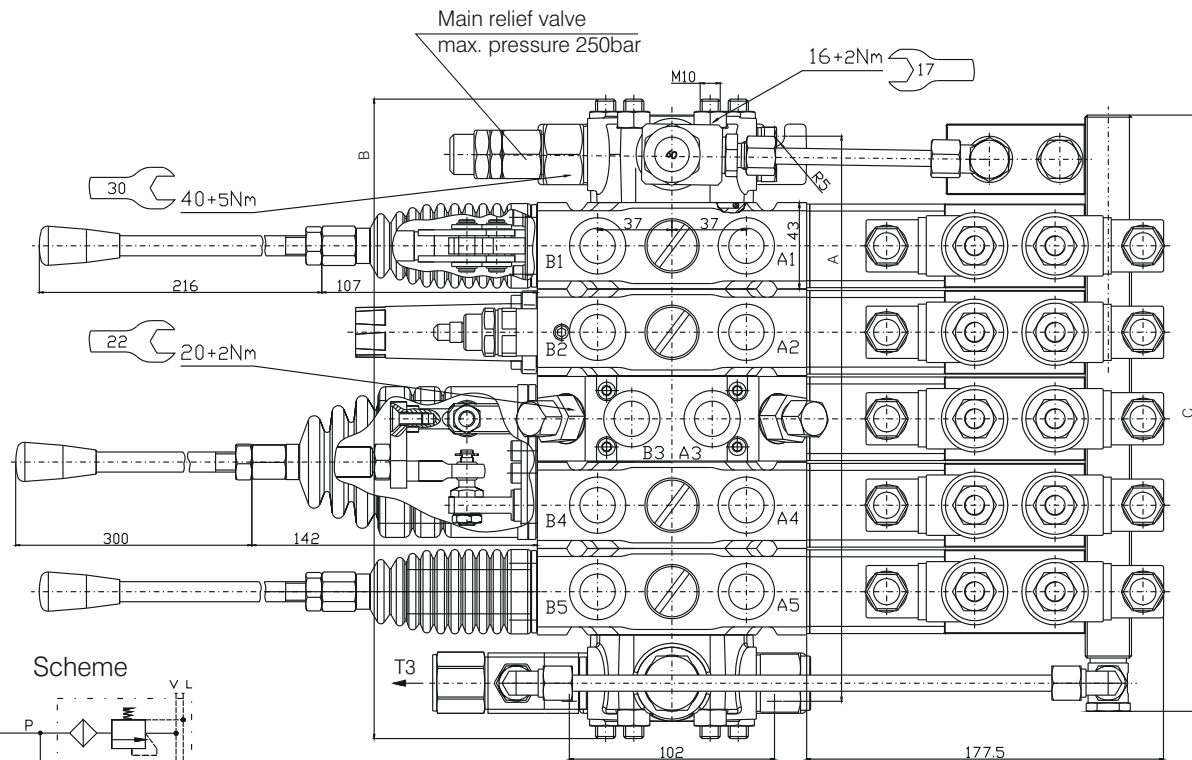
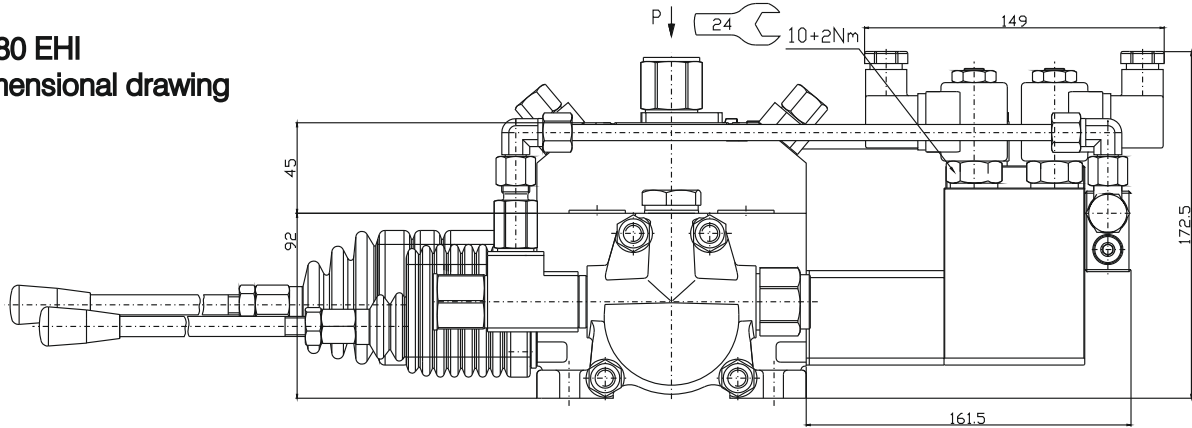

Scheme

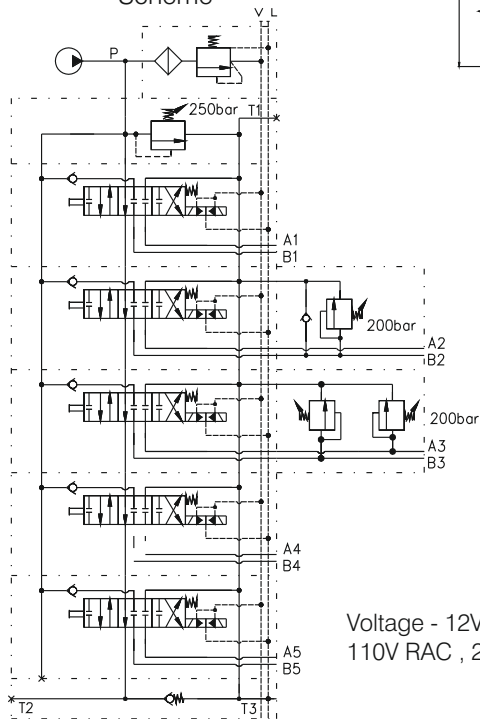



Voltage - 12V DC , 24V DC
110V RAC , 220V RAC

N. of sections	Dimension A mm (in)	Dimension B mm (in)	Dimension C mm (in)
1	109(4.29)	146(5.75)	125(4.92)
2	152(5.98)	189(7.44)	168(6.61)
3	195(7.68)	232(9.13)	211(8.31)
4	238(9.37)	275(10.83)	254(10)
5	281(11.06)	318(12.52)	297(11.69)

Internal pilot (EHI) consist of block with filter and pressure reducing valve , collector , back pressure valve (in the end cover) and pipes.
External pilot (EHE) operating features - max. flow 8l/min.
On/off electrohydraulic control operating features:
-pilot pressure min.10bar ; max. 50bar.
-max. flow 8l/min.
-filtration 25µm.

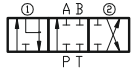
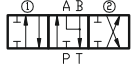
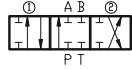
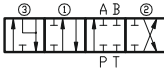
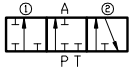
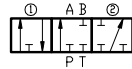
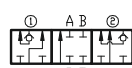
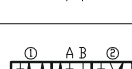
SPOOLS
RP80&RP60

CODE	SCHEME	DESCRIPTION
1		Double acting , 3 position , 4 way A and B to tank in ① .
2		Double acting , 3 position , 4 way A and B to tank in neutral.
3		Double acting , 3 position , 4 way A and B blocked in neutral.
4		Double acting , 4 position , 4 way A and B to tank in ③ (Float plunger).
5		Single acting on A , 3 position , 3 way , A blocked in neutral.
6		Single acting on B , 3 position , 3 way , B blocked in neutral.
7		Double acting , 3 position , 4 way A and B blocked in neutral. Series connection. Special spool required. Max. flow 30l/min. FOR RP60 ONLY.
8		Double acting , 3 position , 4 way , B to T in neutral. P to A and B in ① . Special body with extra machining required. FOR RP60 ONLY.
9		Double acting , 3 position , 4 way , B to T in neutral. FOR RP60 ONLY.

SPOOL CONTROL
RP80&RP60

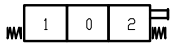
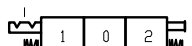
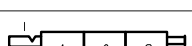
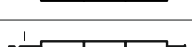
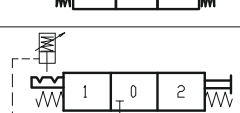
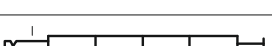
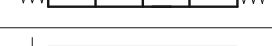
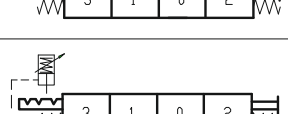
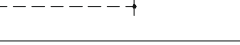
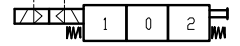
CODE	SCHEME	DESCRIPTION
1		Spring return to neutral (position 0).
2		Detent in position 1 or 2. Spring return to neutral.
3		Detent in position 2. Spring return to neutral.
4		Detent in position 1. Spring return to neutral.
5		Detent in two positions with kick-out to neutral from positions 1 , 2. Release pressure adjustable from 60 to 180bar. Special spool required. FOR RP80 ONLY.
6		Detent in position 3. Spring return to neutral.
7		Detent in three positions. Spring return to neutral.
8		Detent in three positions with kick-out to neutral from positions 1 , 2. Release pressure adjustable from 60 to 180bar. Special spool required. FOR RP80 ONLY.
9		On/Off electropneumatic control - EPC. Spring return to neutral.
10		On/Off electrohydraulic control. Spring return to neutral.

INLET COVER

RP80&RP60

CODE	SCHEME	DESCRIPTION
Q		Top inlet Pilot operated relief valve for RP80 Directly operated relief valve for RP60
K		Shut-off plug installed

OUTLET COVER

RP80&RP60

CODE	SCHEME	DESCRIPTION
R		Open center
W		Closed center. Shut-off plug installed
C		Carry over. Shut-off plug installed

ORDERING CODE

RP80

RP 80 EHI / 3 / Q / M80 P 3 EL 10-12 B E1 RVACB / R / 2 / G N

Mechanical control - Omit
Electrohydraulic control internal pilot - EHI
Electrohydraulic control external pilot - EHE
Electropneumatic control - EPC

Number of operating sections 1...10

Inlet cover

Circuit
-parallel P
-tandem T
-combinations P+T C

Spool type

Lever mechanism

Spool control type

Voltage:
for spool control type 9 ; 10

12V DC	- 12
24V DC	- 24
110V RAC	- 11
220V RAC	- 22

Lever position:
EHE , EHI - B port side only

A-port side	Code A
B-port side	Code B

Application:
N - normal
T - tropic

Standard port threads:
G - G1/2" (ISO 228)
M - M22x1,5 (ISO6149)
Special threads on request

Main relief valve setting-bar/psi

Code	
1	30...320 (400...4570)
2	15...200 (210...2850)

Outlet cover

Auxiliary valves:

Code	
RVA	relief valve -port A
RVB	-port B
RVAB	-port A & B
CA	combining port relief and anticavitation valve -port A
CB	-port B
CAB	-port A & B
KA	anticavitation valve -port A
KB	-port B
KAB	-port A & B

Code Omit without microswitch
Micro switch:

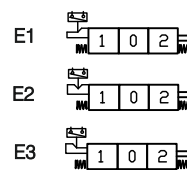

see page 6/14

* Repeat for each section. In case of identical section example ordering code is: RP80 / 5 / Q / 2x / / 3x / / R / 2 / G

RP 60 EHI / 3 / Q / M60 P 3 SL 10-12 B E1 RVACB / R / 2 / 1/2 N

First section

Mechanical control - Omit
 Electrohydraulic control internal pilot - EHI
 Electrohydraulic control external pilot - EHE
 Electropneumatic control - EPC

Number of operating sections 1...10

Inlet cover

Circuit

-parallel
 -tandem
 -combinations P+T

Code

P
 T
 C

Spool type

Lever mechanism

Spool control type

Voltage:
 for spool control type 9 ; 10

12V DC - 12
 24V DC - 24
 110V RAC - 11
 220V RAC - 22

Code

Lever position:
 EHE , EHI - B port side only

A-port side A
 B-port side B

Application:
 N - normal
 T - tropic

Standard port threads:
 P , T , A , B - G1/2" or G3/8"
 1/2" - G1/2"
 3/8" - G3/8"
 Special threads on request

Main relief valve setting -bar/psi

Standard setting:
 Omit - 96...210(1370...3000)
 1 211...320(3000...4570)
 2 30...100(400...1400)

Outlet cover

Code

RVA relief valve -port A
 RVB -port B
 RVAB -port A & B
 CA combining port relief and anticavitation valve-port A
 CB -port B
 CAB -port A & B
 KA anticavitation valve -port A
 KB -port B
 KAB -port A & B

Auxiliary valves:

Code

Omit without microswitch



Micro switch:

see page 6/14

* Repeat for each section. In case of identical section example ordering code is: RP60 / 4 / Q / 2x / MP3SL1BRVA / 2x / MP3SL9B / R / 2 / G1/2

NOTE: Auxiliary valves build into sectional body. The valve pressure setting specify in order.

HYDRAULIC CIRCUIT APPLICATIONS

RP80&RP60

WITH PORT RELIEF VALVE

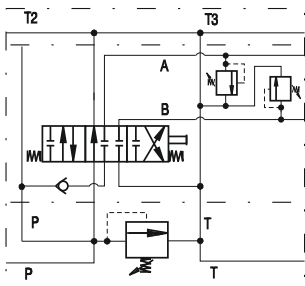

WITH ELECTRO-PNEUMATIC CONTROL

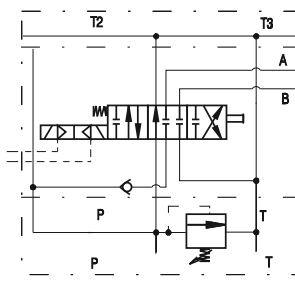

WITH COMBINED PORT RELIEF AND ANTICAVITATION VALVES

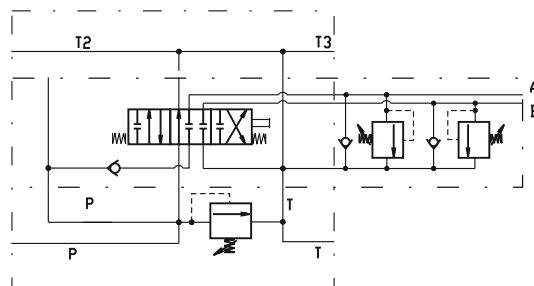

NOTE: Different applications of RP80 and RP60 are available on request. Consult factory for more technical data and performance curves

CONDITIONS:
 $\Delta P=f(Q)$
 36 cSt oil viscosity
 $T=40^{\circ}\text{C}(104^{\circ}\text{F})$

Pressure drop

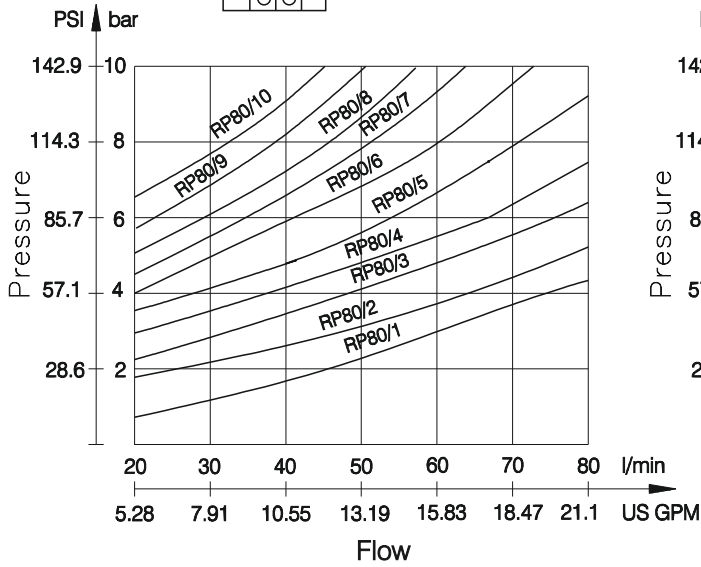
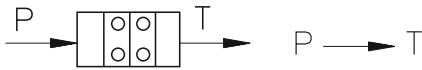

Pressure drop

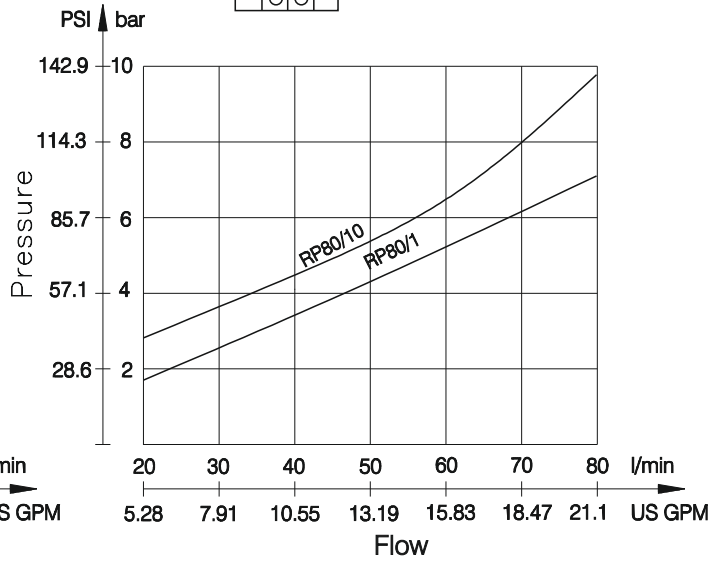

Pressure drop

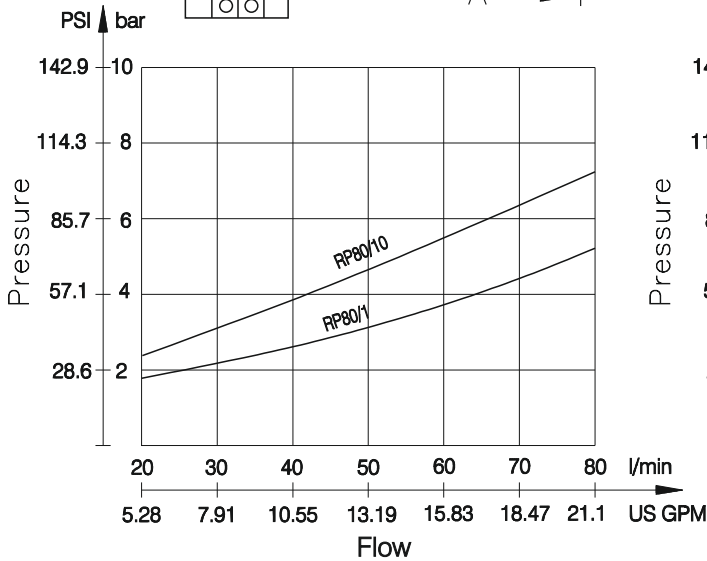

Spool leakage

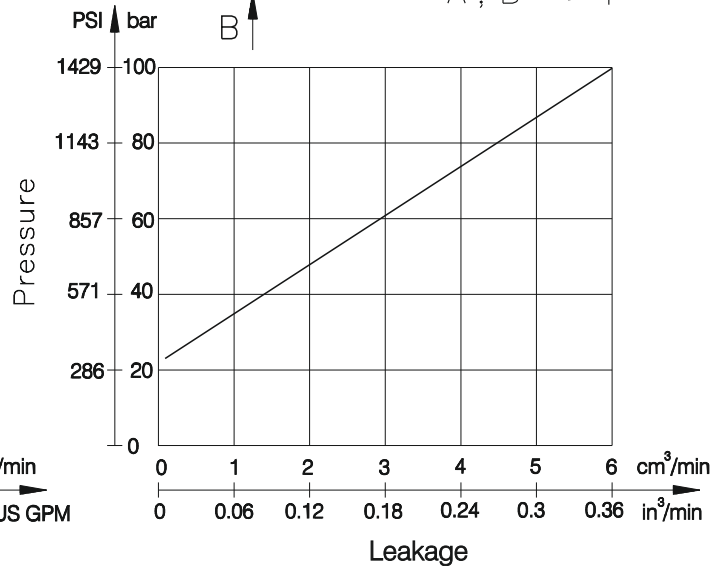

CONDITIONS:
 $\Delta P=f(Q)$
 36 cSt oil viscosity
 $T=40^{\circ}\text{C}(104^{\circ}\text{F})$

Pressure drop
 $P \rightarrow T$

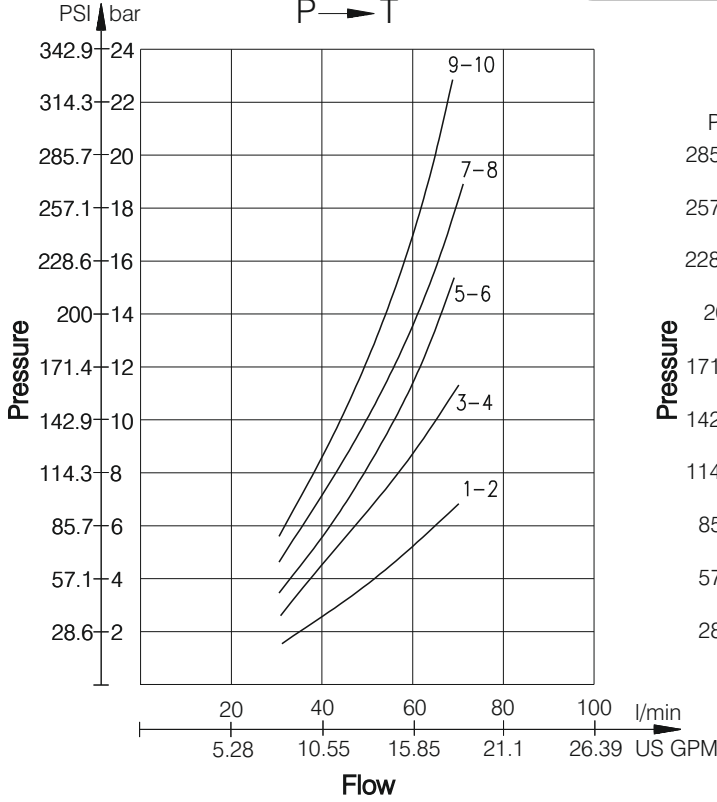

Pressure drop
 $P \rightarrow A, B$

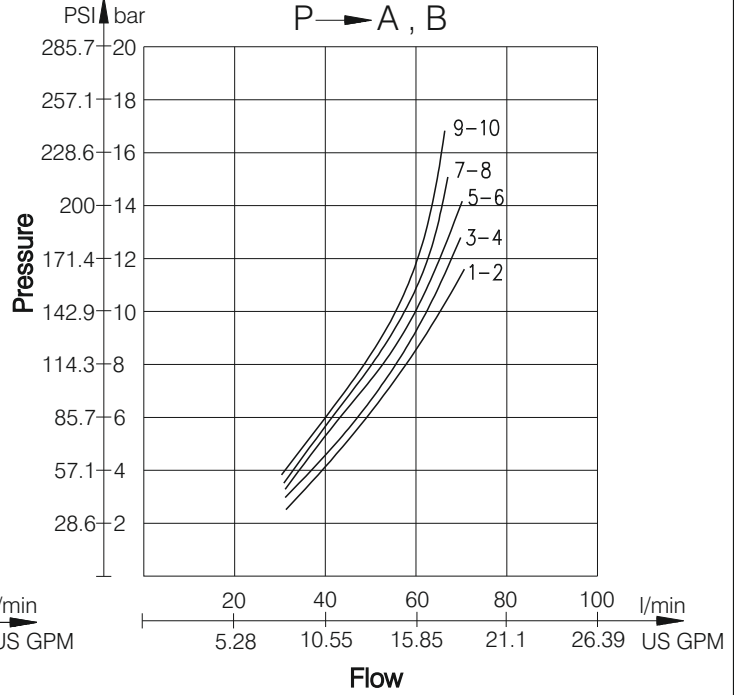

Pressure drop
 $A \rightarrow T$

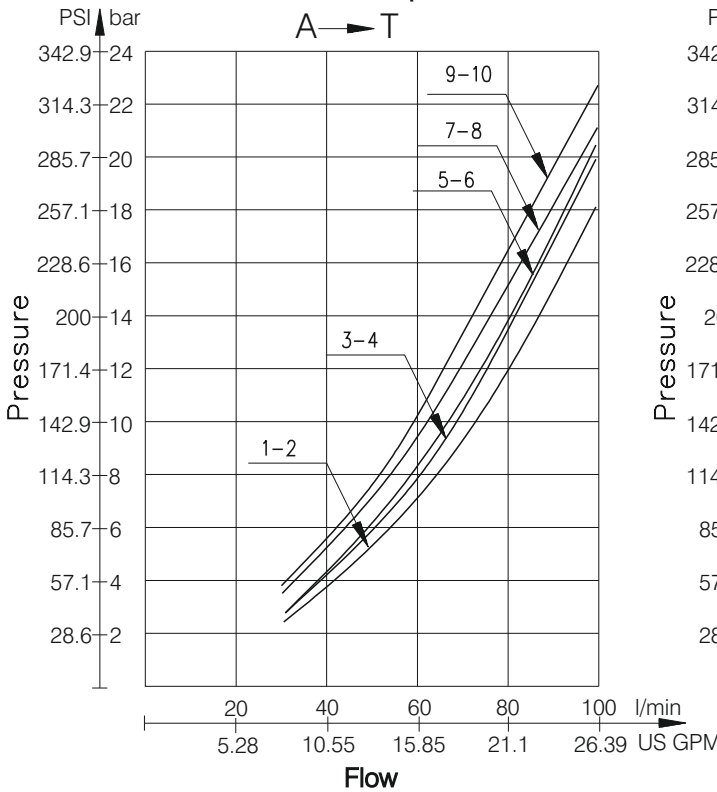

Pressure drop
 $B \rightarrow T$

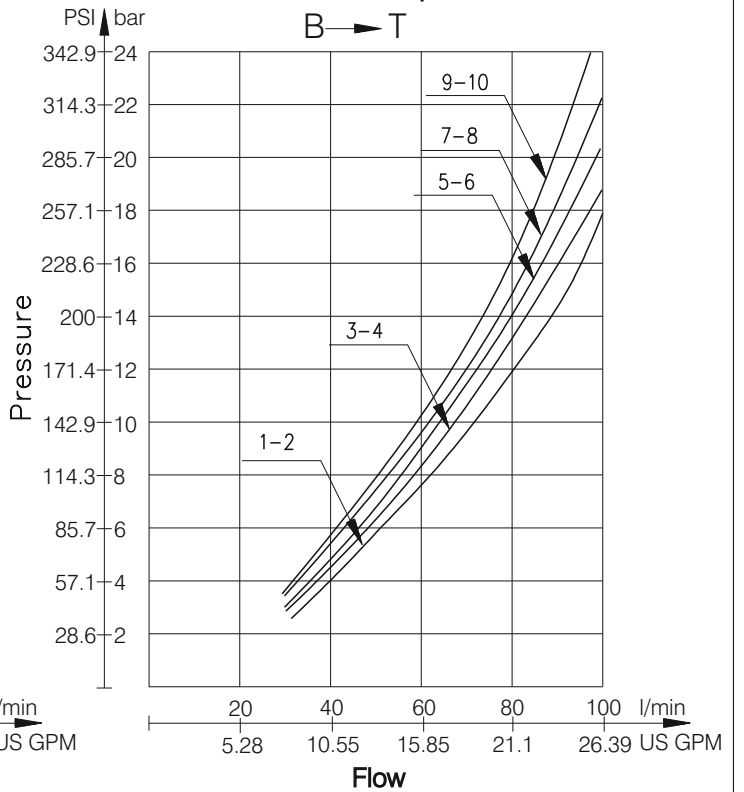



caproni
BULGARIA JOINT-STOCK COMPANY

**BULGARIA , 6100 KAZANLAK , 45 STOLETOV STR.
TEL.:+359/431/62 229 , +359/431/6132 ,
FAX:+359/431/62 230 , +359/431/63 134
E-MAIL:CAPRONI@CAPRONI.BG , WEB:HTTP://WWW.CAPRONI.BG**